

ESPECIFICACIONES TÉCNICAS

Voltaje	12-24VCD
AMP	1.3
DB	87 / 107 a 1m
Sonido	Autoajustable
IP	66
Usos	

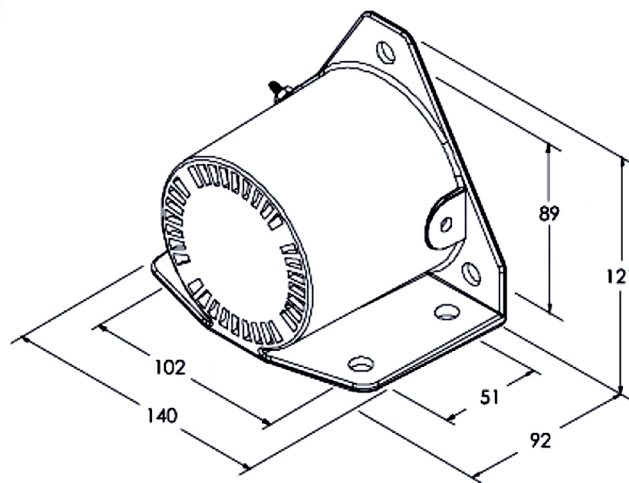

Alarma de reversa 12-24VCD resistente al agua y polvo, etc. Es fácil de instalar, diseñada para aplicaciones exigentes.



Unidad: mm

4  **RUV 4**
Protegido contra rayos UV en exteriores

UV

6  **Protegido contra polvo.**

SOLIDOS

6  **Protegido contra fuertes chorros de agua, poca entrada.**

LIQUIDOS